

EX3215
EX3216^{-01/222(K)}

EX3215
EX3216^{-02/223(K)}

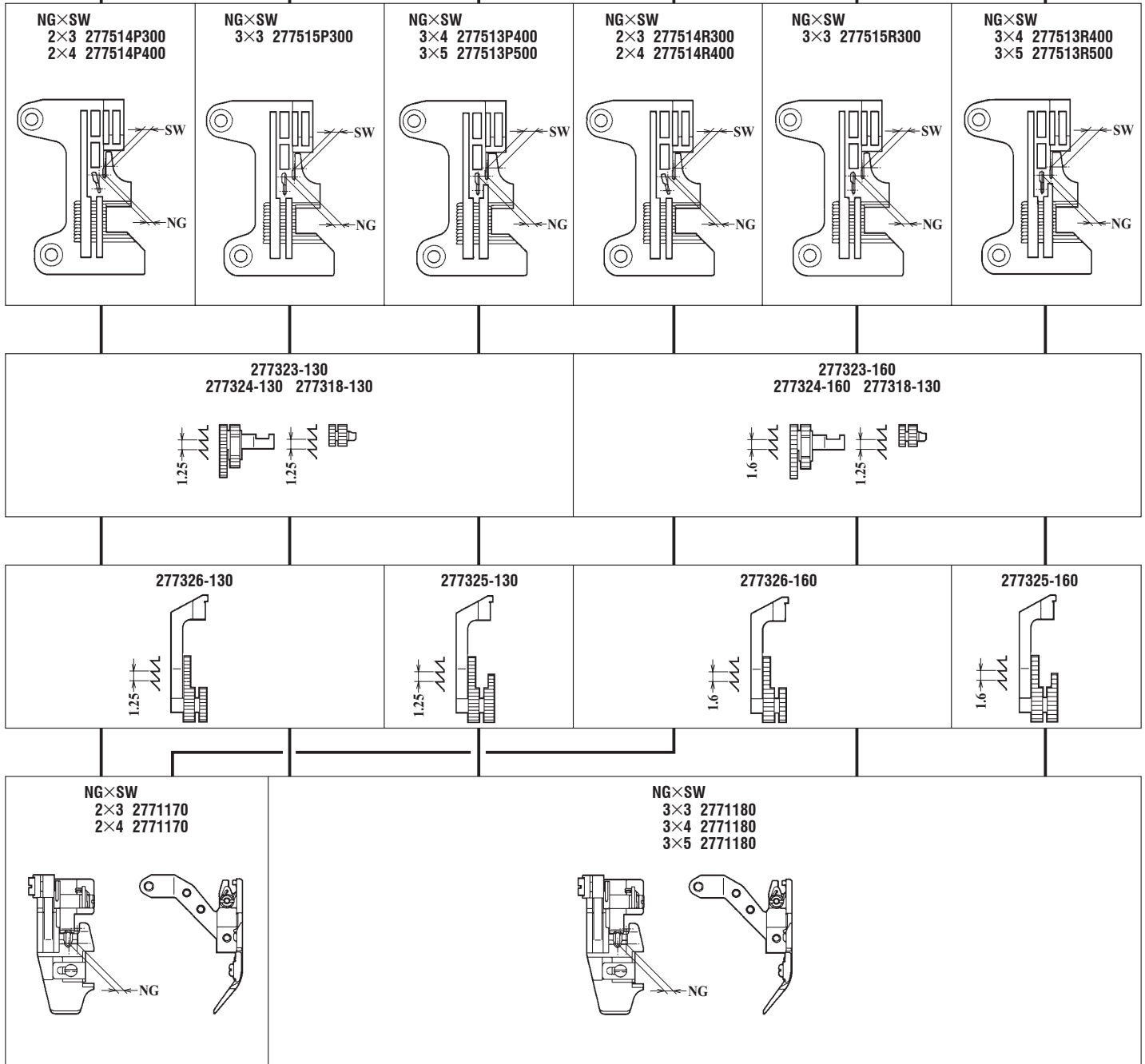

EX3215-01/222(K)
EX3216

EX3215-02/223(K)
EX3216

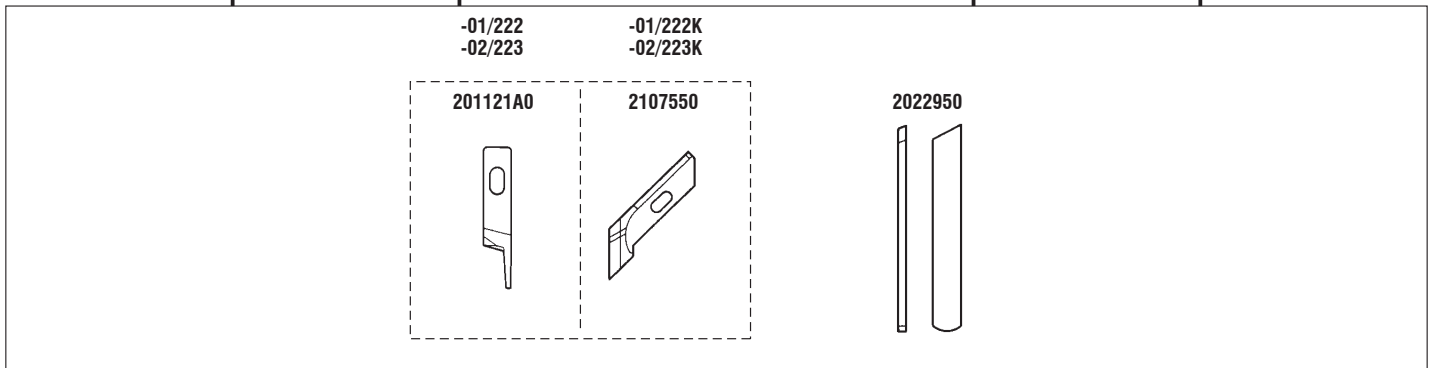
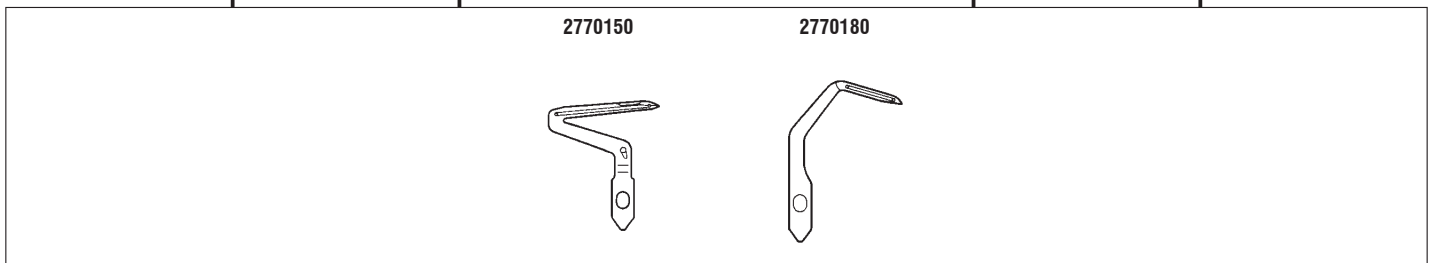
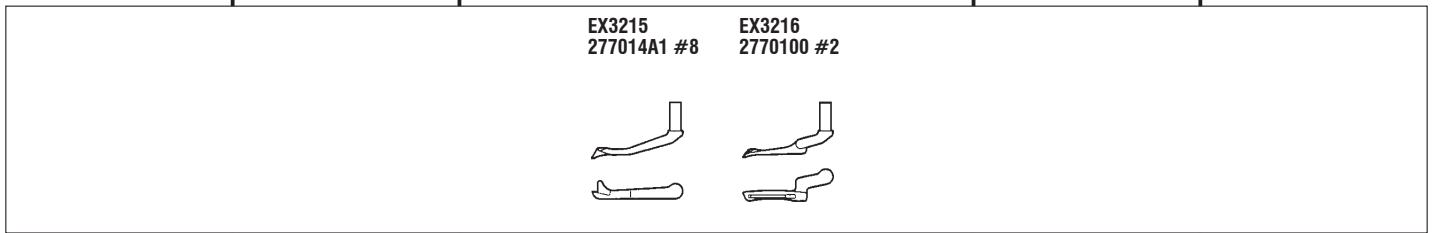
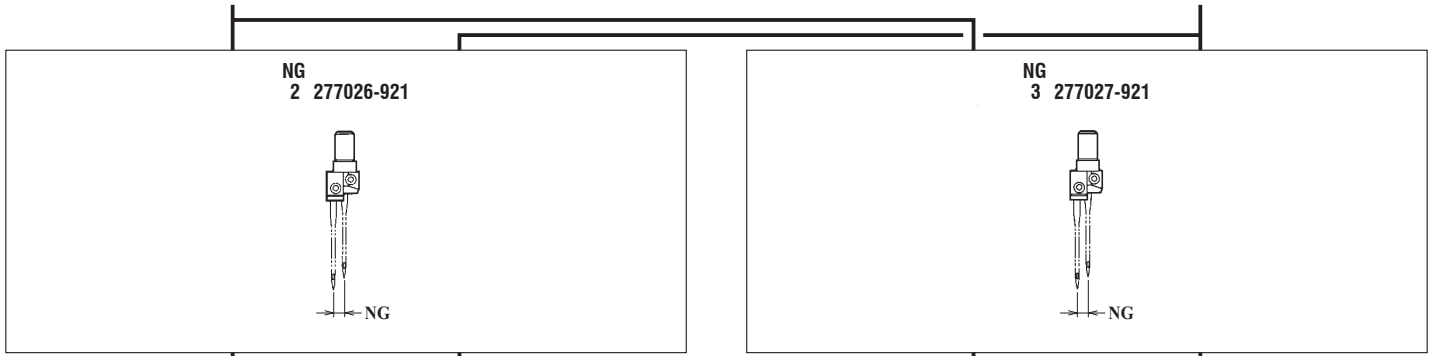

地縫用 (極薄~薄生地)
PLAIN SEAMING
(EXTRA LIGHT~LIGHT WEIGHT FABRIC)

地縫用 (薄~中厚生地)
PLAIN SEAMING
(LIGHT~MEDIUM WEIGHT FABRIC)

EX3200Series
共通部品 COMMON PARTS

オーバーロック針受 OVERLOCK NEEDLE GUARD

2770070



2770040



二重環針受 CHAINSTITCH NEEDLE GUARD

2770080



2770060 標準(Standard)
277006A0 EX3215N-01U
EX3215-02U,03U

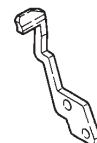

EX3215
EX3216^{-01A/222}

EX3215
EX3216^{-02A/223}

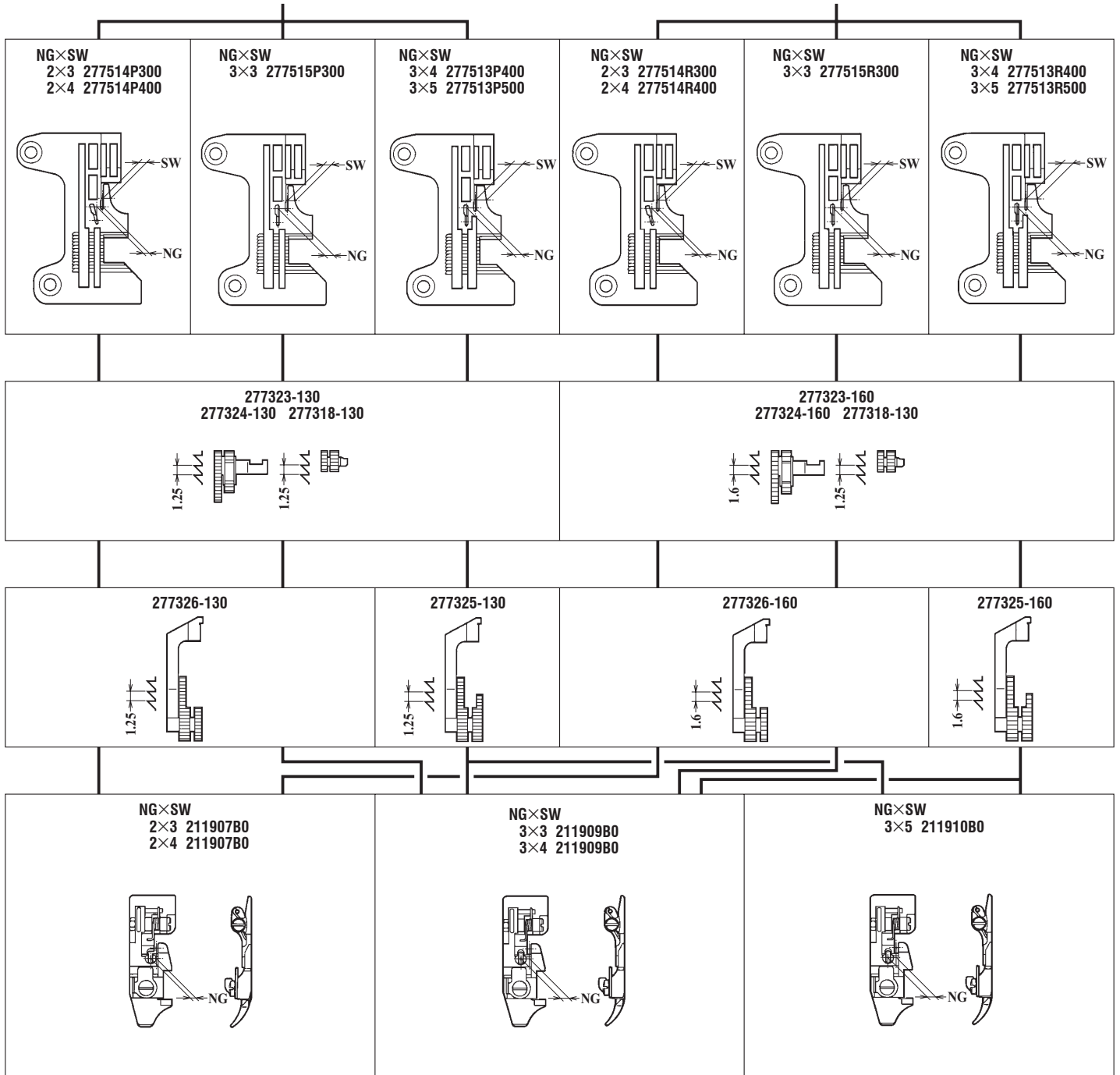

EX3215-01A/222
EX3216

EX3215-02A/223
EX3216

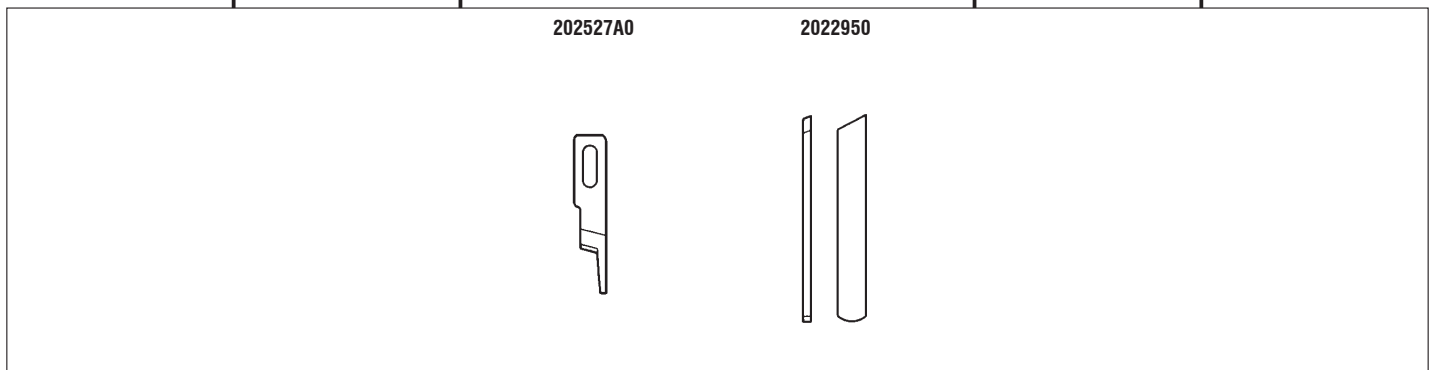
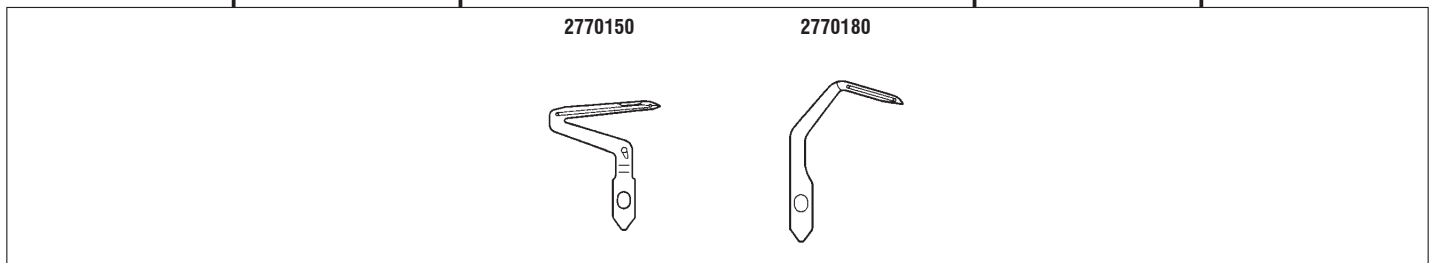
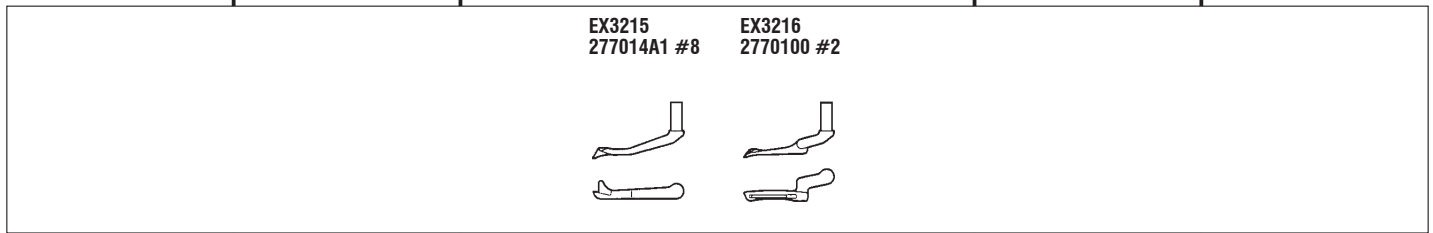
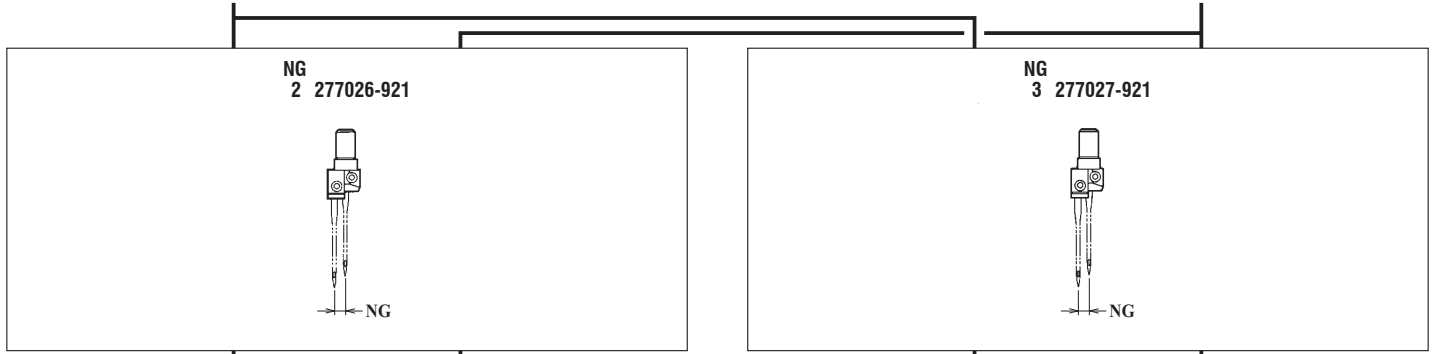

地縫用 (極薄~薄生地)
PLAIN SEAMING
(EXTRA LIGHT~LIGHT WEIGHT FABRIC)

地縫用 (薄~中厚生地)
PLAIN SEAMING
(LIGHT~MEDIUM WEIGHT FABRIC)

EX3215N
EX3216N-01/222

EX3215N
EX3216N-01/232

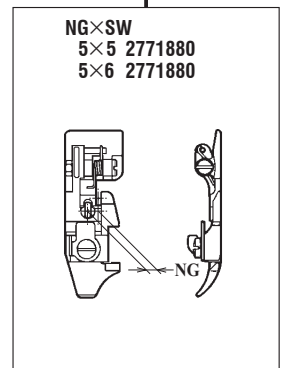
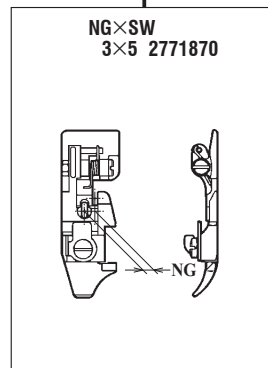
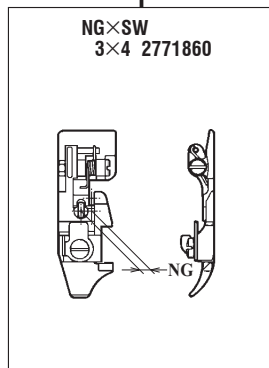
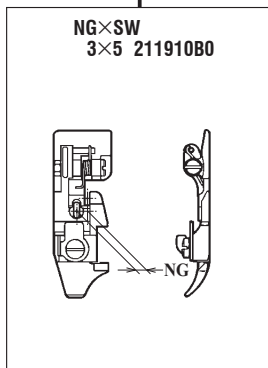
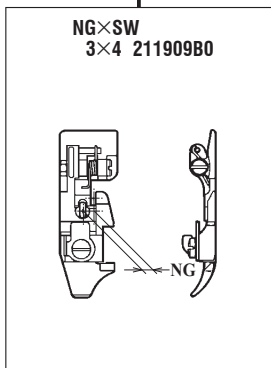
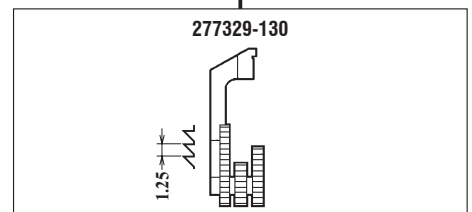
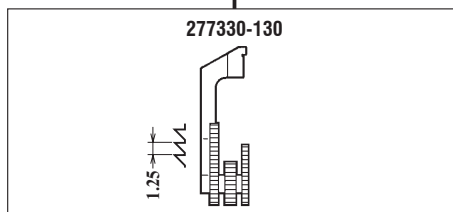
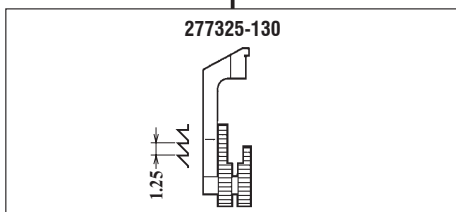
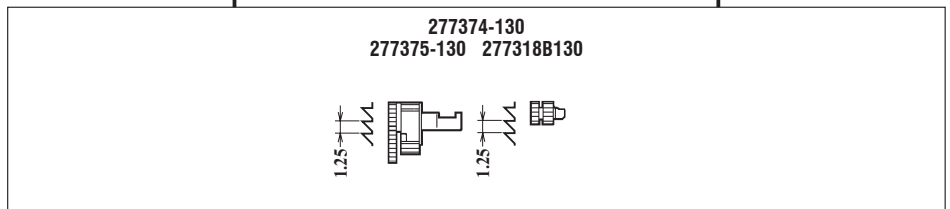
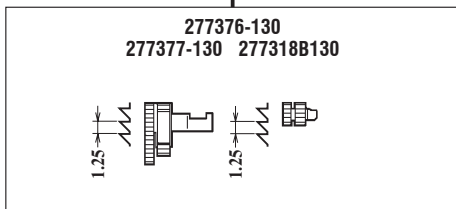
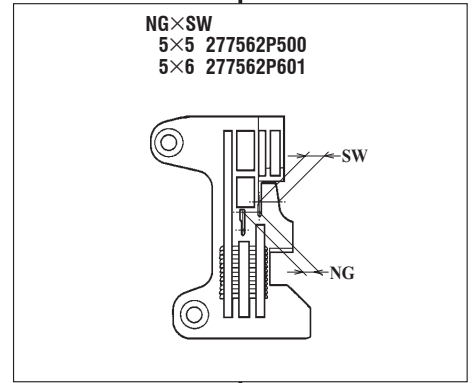
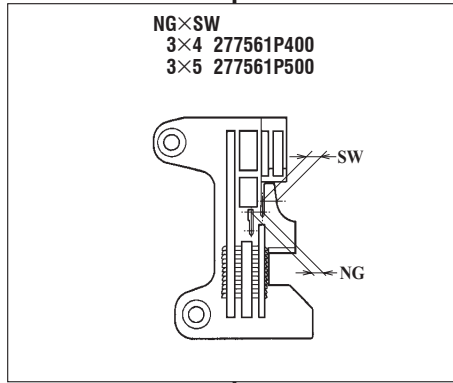
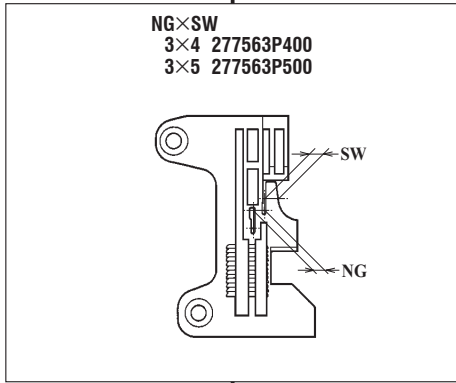

EX3215N
EX3216N-01/222

EX3215N
EX3216N-01/232

NG
3 277027-921

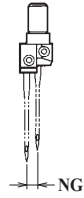

NG
5 277028-920

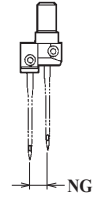

EX3215N
277014A1 #8

EX3216N
2770100 #2

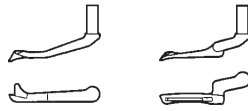

2770150

2770180

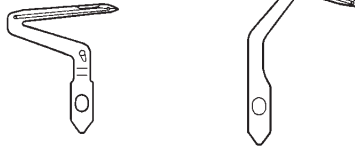

202527A0

2022950

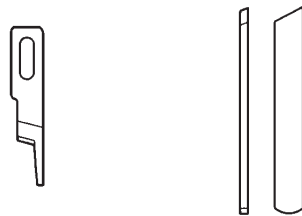

地縫用 (極薄~薄生地)
PLAIN SEAMING
(EXTRA LIGHT~LIGHT WEIGHT FABRIC)

地縫用 (極薄~薄生地)
PLAIN SEAMING
(EXTRA LIGHT~LIGHT WEIGHT FABRIC)

EX3215N-01S/272
EX3216N

EX3215N-01U/232
EX3216N

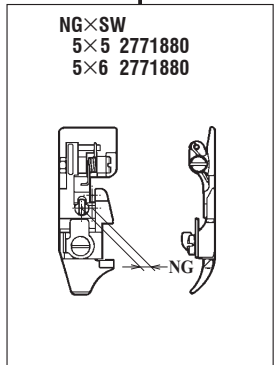
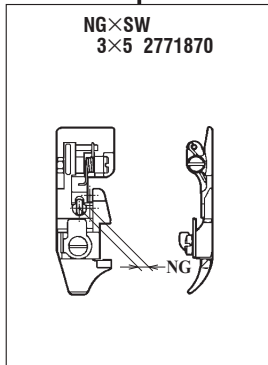
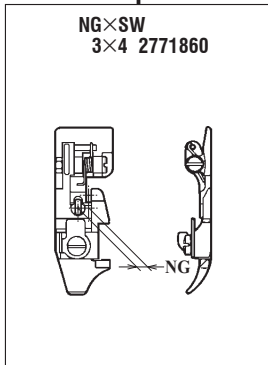
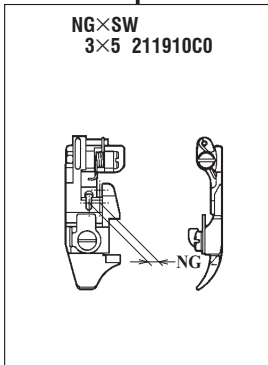
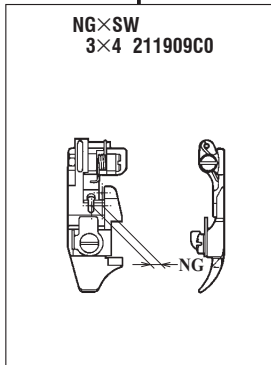
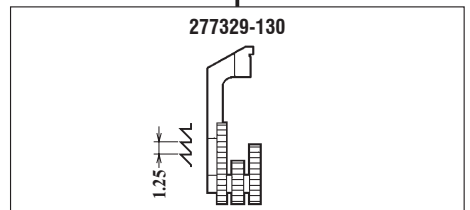
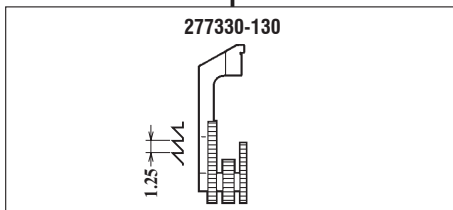
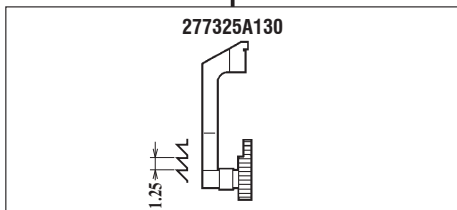
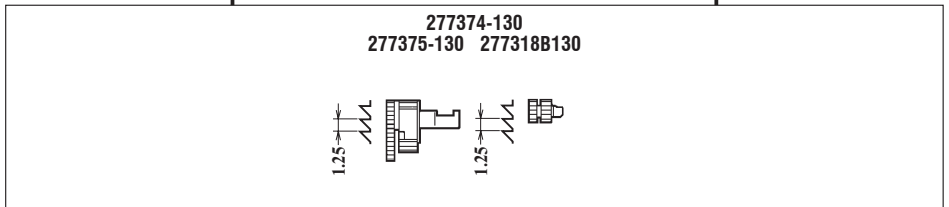
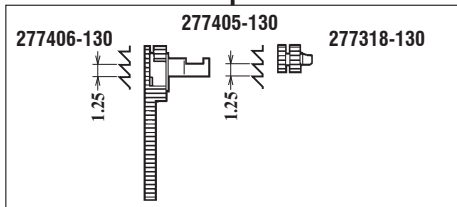
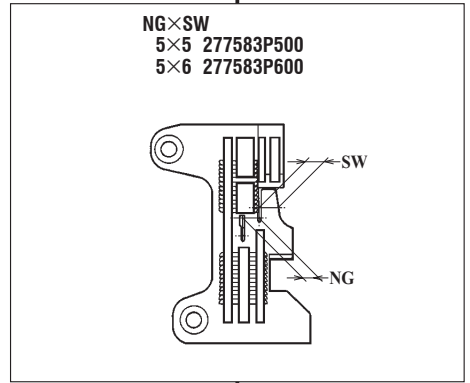
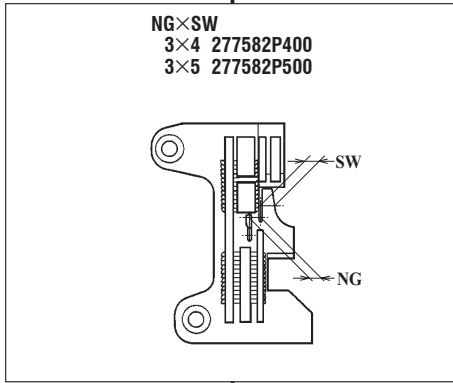
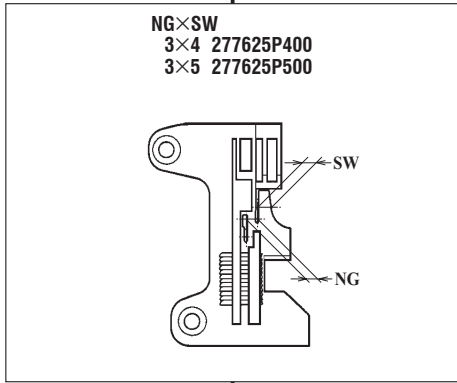

EX3215N
EX3216N-01S/272

EX3215N
EX3216N-01U/232

NG
3 277027-921

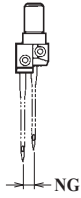

NG
5 277028-920

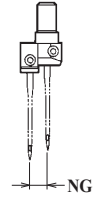

EX3215N
277014A1 #8

EX3216N
2770100 #2

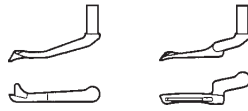

2770150

2770180

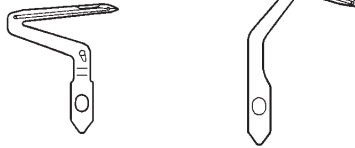

202527A0

2022950

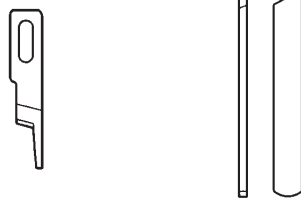

地縫用 (極薄~薄生地)
PLAIN SEAMING
(EXTRA LIGHT~LIGHT WEIGHT FABRIC)

地縫用 (極薄~薄生地)
PLAIN SEAMING
(EXTRA LIGHT~LIGHT WEIGHT FABRIC)

EX3215-02A/233
EX3216

EX3215-02U/223(K)
EX3216

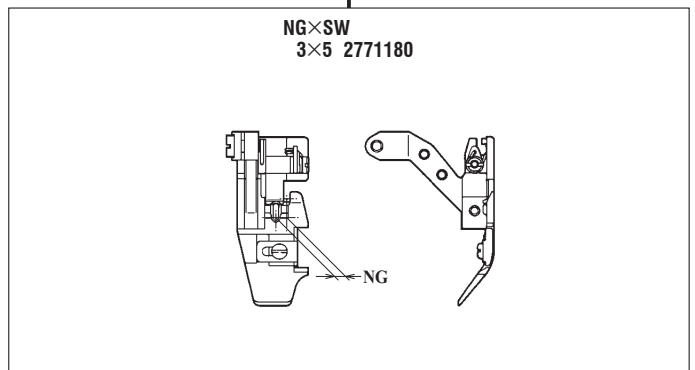
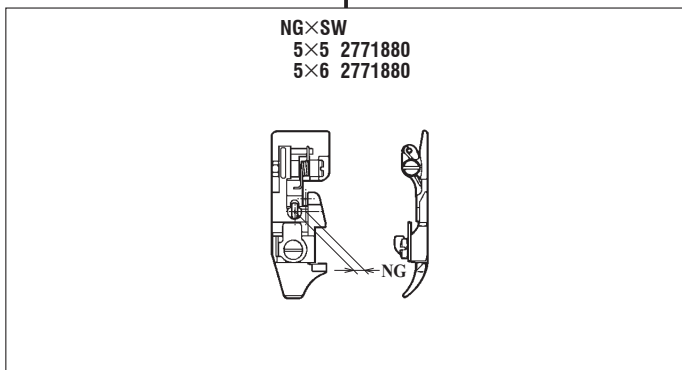
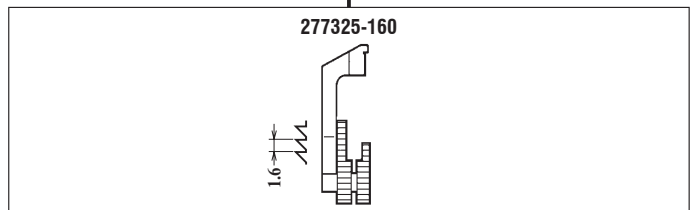
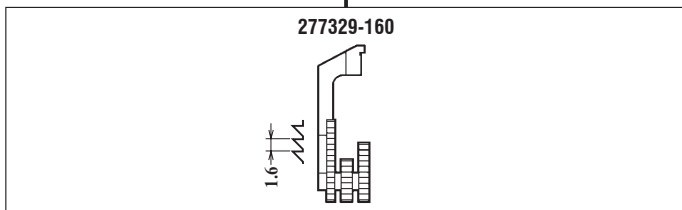
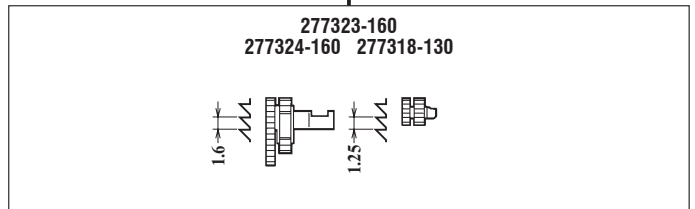
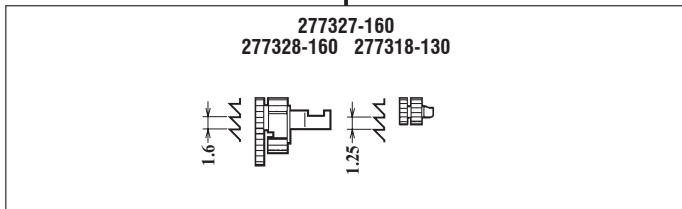
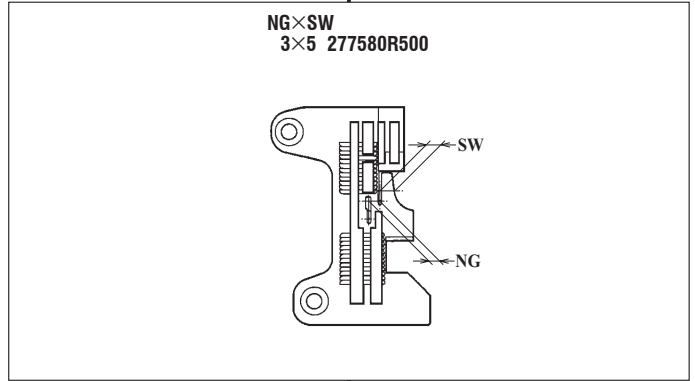
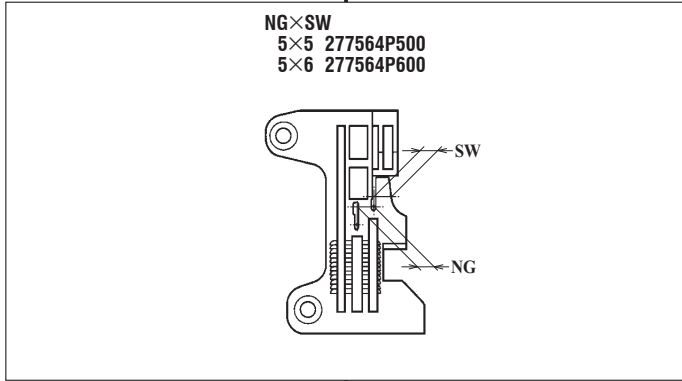

EX3215-02A/233
EX3216

EX3215-02U/223(K)
EX3216

NG
5 277028-920

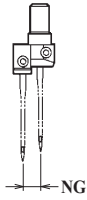

NG
3 277027-921

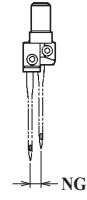

EX3215
277014A1 #8

EX3216
2770100 #2

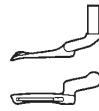

2770150

2770180

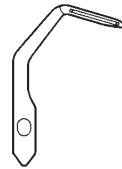
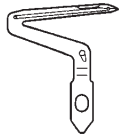

-02A/233

-02U/223

-02U/223K

202527A0

201121A0

2107550

2022950

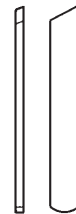
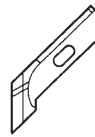

地縫用 (薄~中厚生地)
PLAIN SEAMING
(LIGHT~MEDIUM WEIGHT FABRIC)

地縫用 (薄~中厚生地)
PLAIN SEAMING
(LIGHT~MEDIUM WEIGHT FABRIC)

EX3215-03/233(K)
EX3216

EX3215-03U/233(K)
EX3216

EX3215-03/333(K)
EX3216

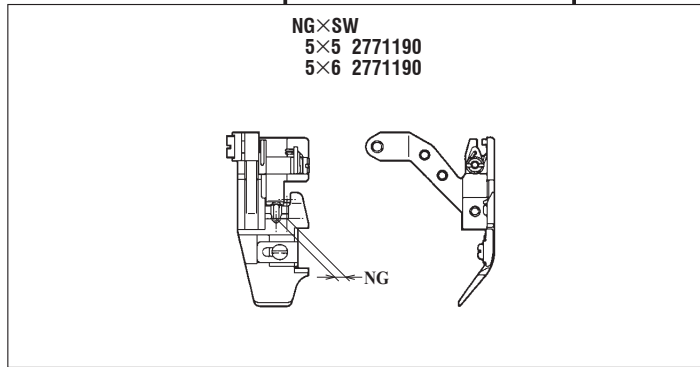
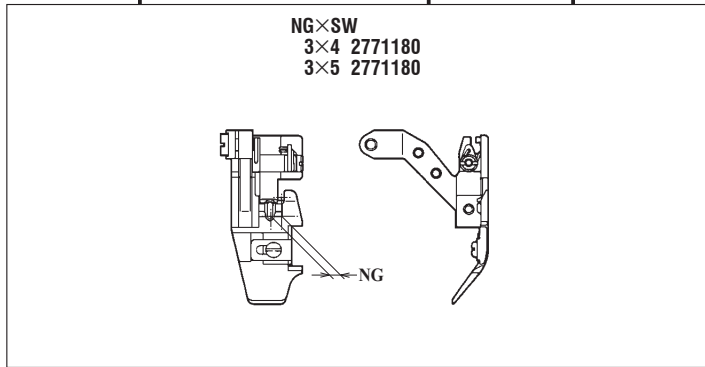
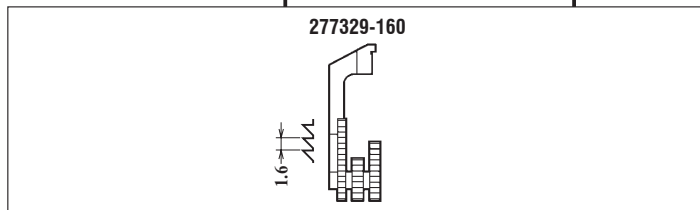
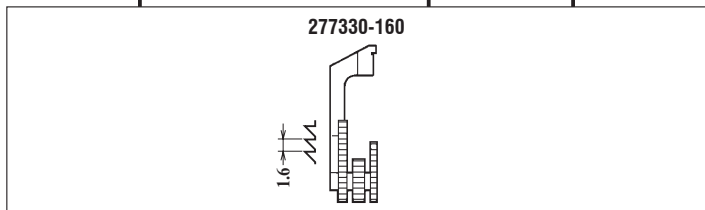
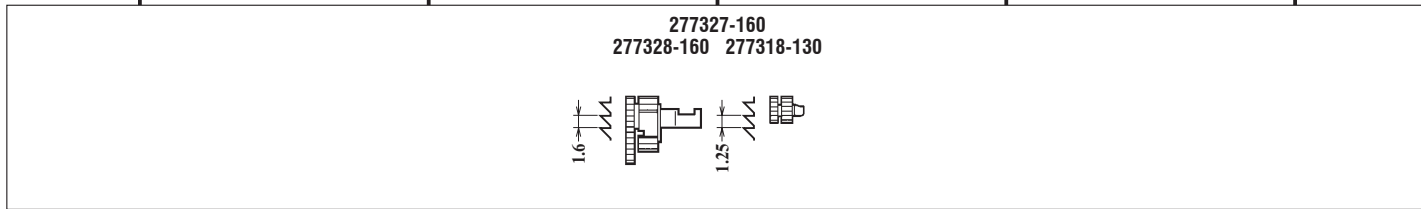
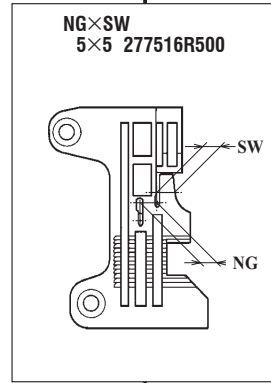
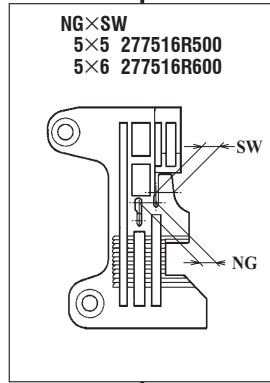
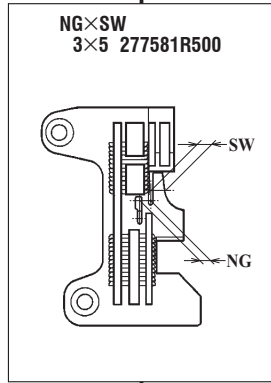
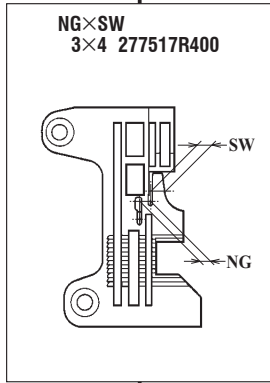
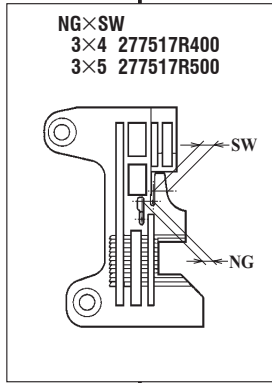

EX3215-03/233(K)
EX3216

EX3215-03U/233(K)
EX3216

EX3215-03/333(K)
EX3216

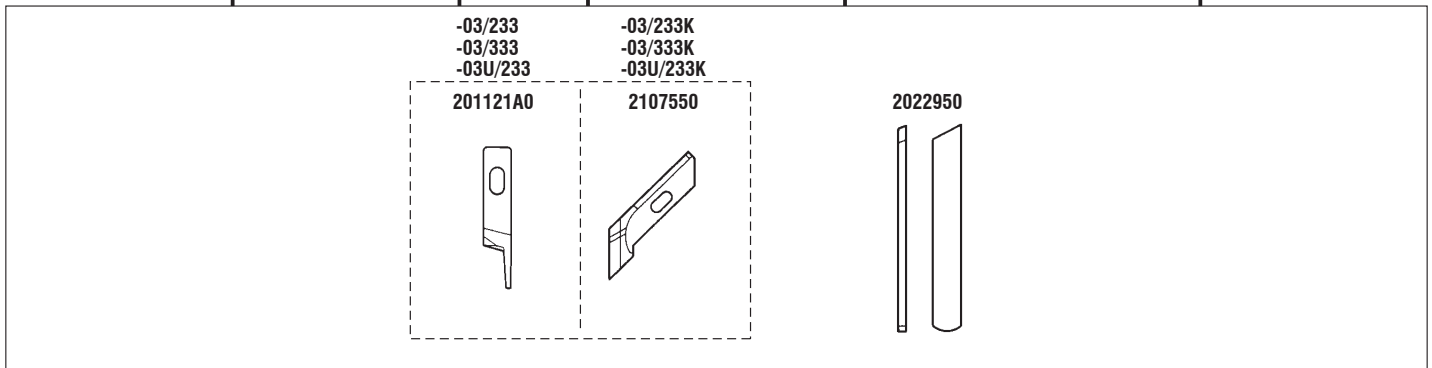
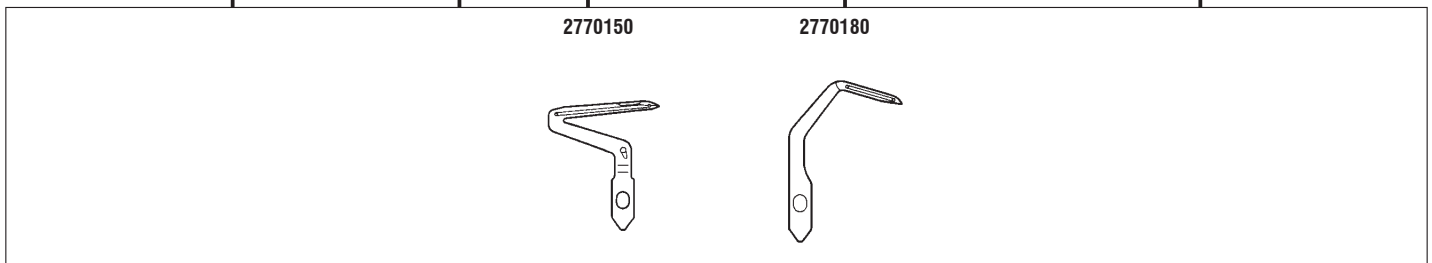
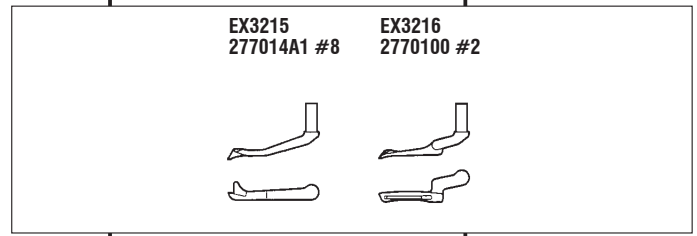
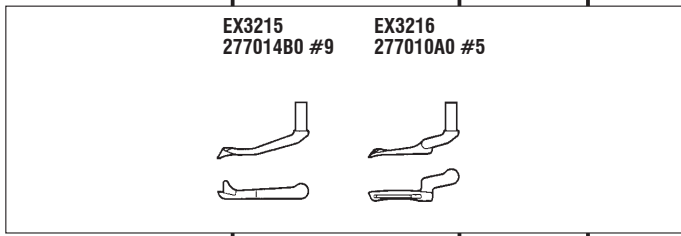
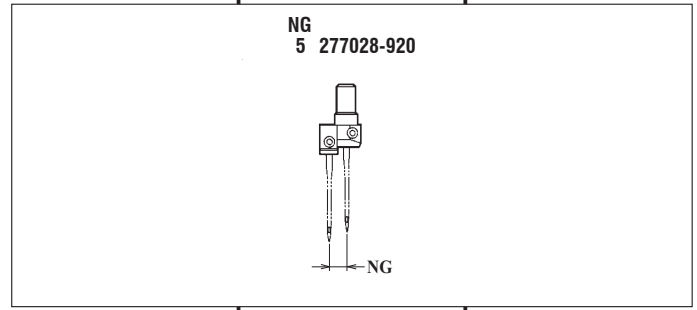
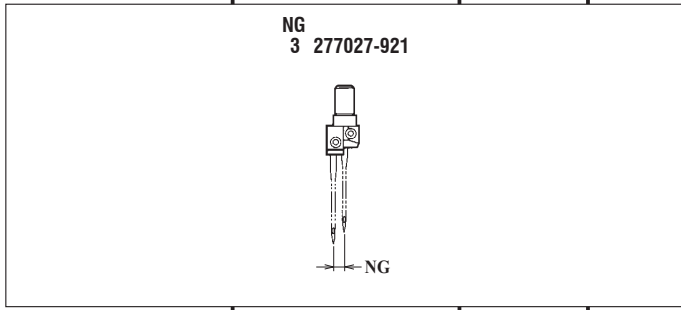

地縫用 (中厚~厚生地)
PLAIN SEAMING
(MEDIUM~HEAVY WEIGHT FABRIC)

地縫用 (中厚~厚生地)
PLAIN SEAMING
(MEDIUM~HEAVY WEIGHT FABRIC)

EX3244-03/333(K)

EX3244-A04/435(K)

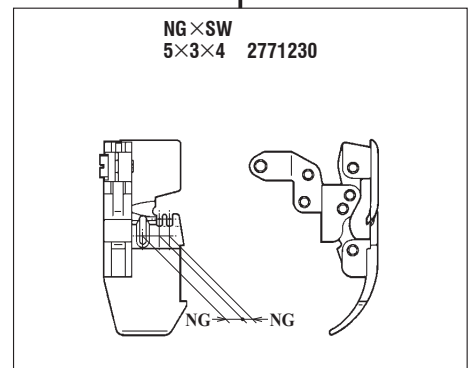
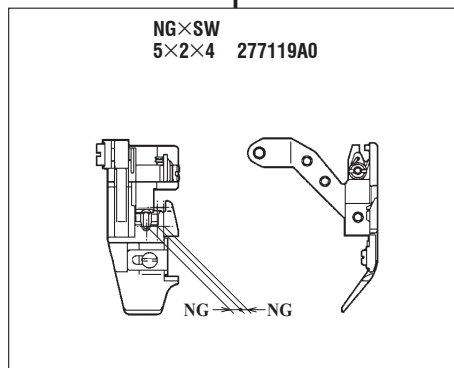
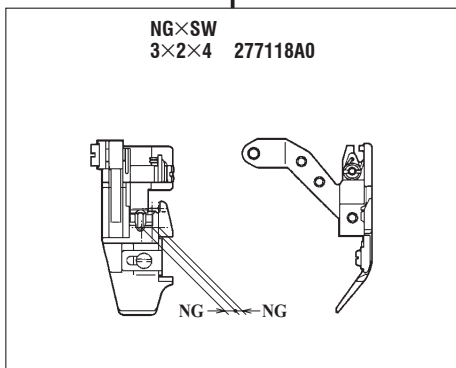
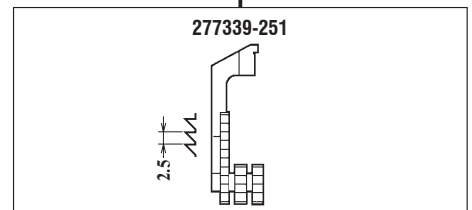
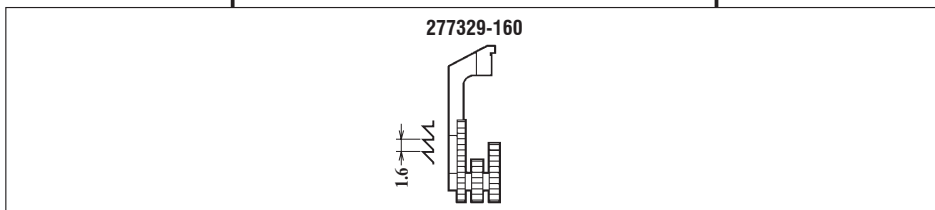
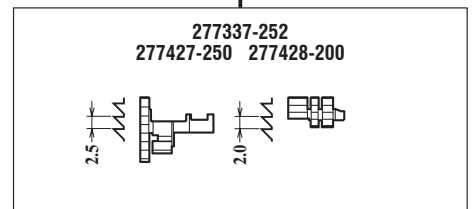
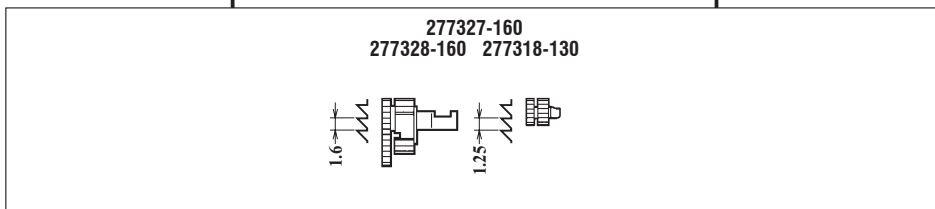
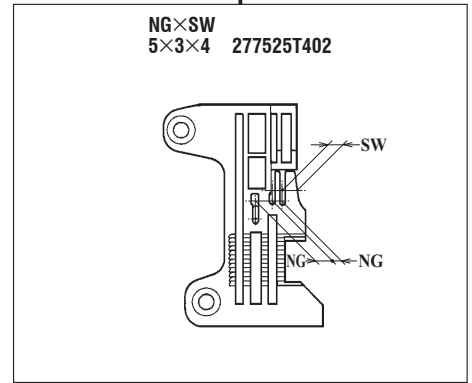
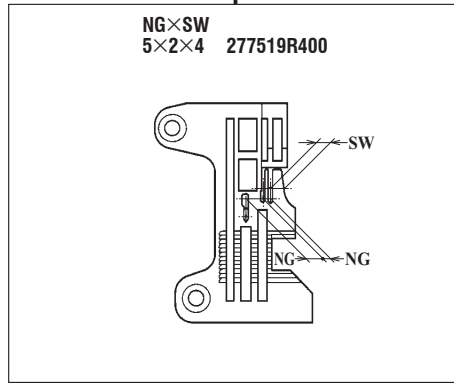
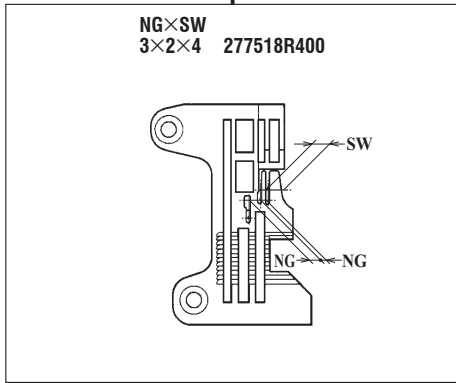

EX3244-03/333(K)

EX3244-A04/435(K)

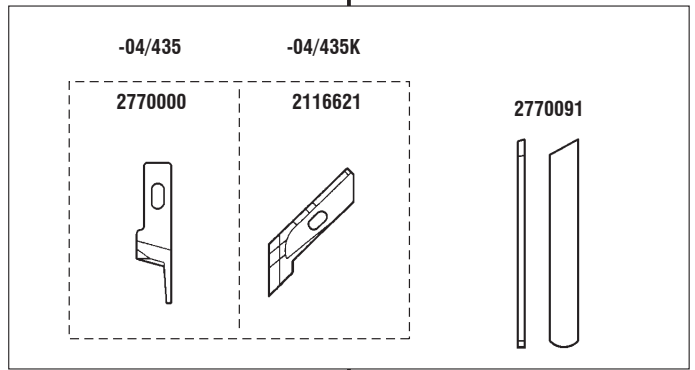
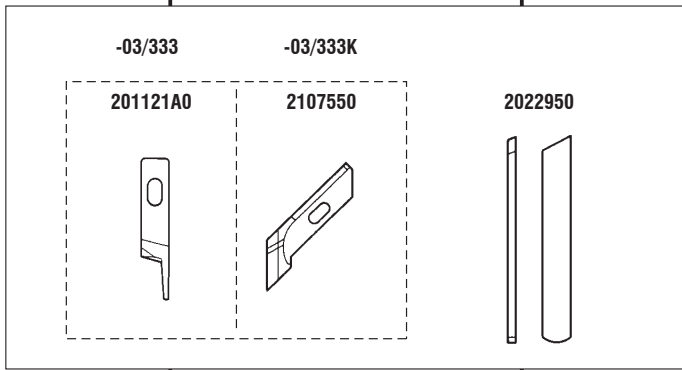
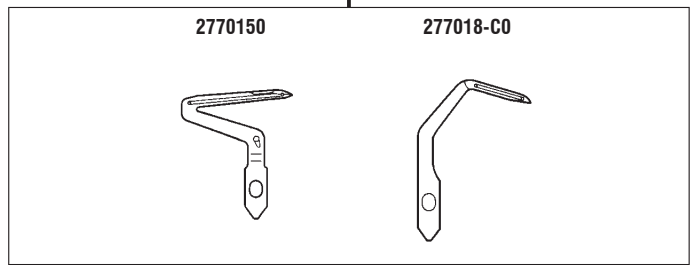
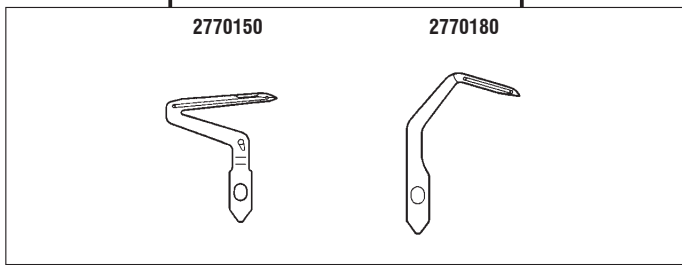
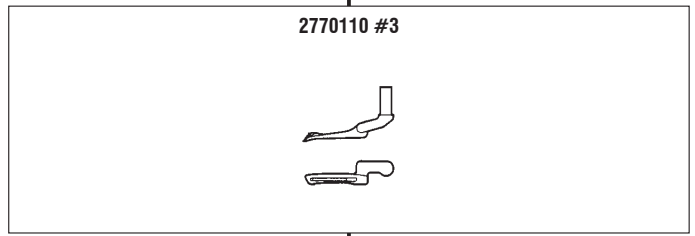
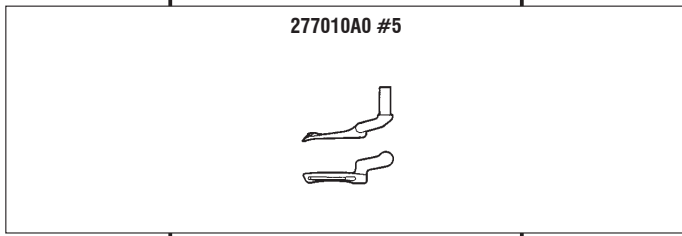
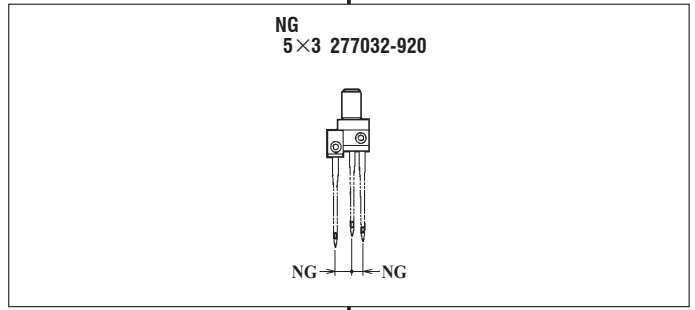
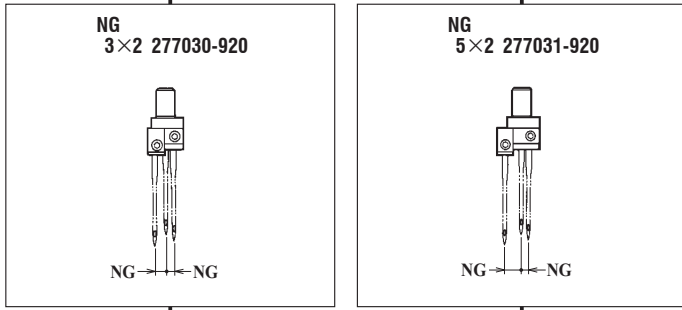

地縫用 (中厚~厚生地)
PLAIN SEAMING
(MEDIUM~HEAVY WEIGHT FABRIC)

地縫用 (厚~極厚生地)
PLAIN SEAMING
(HEAVY~EXTRA HEAVY WEIGHT FABRIC)

EX3215
EX3216^{-A04/435(K)}

EX3215H
EX3216H^{-A05/535(K)}

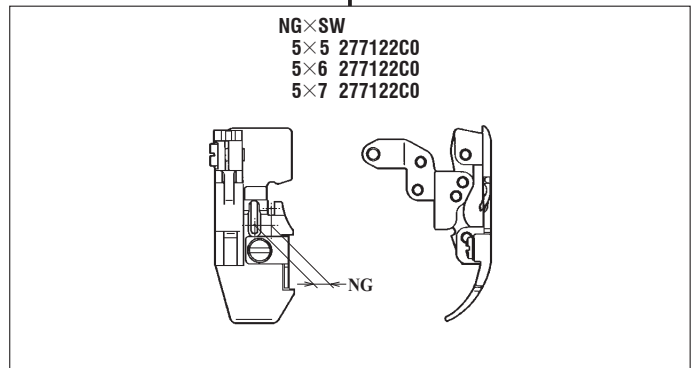
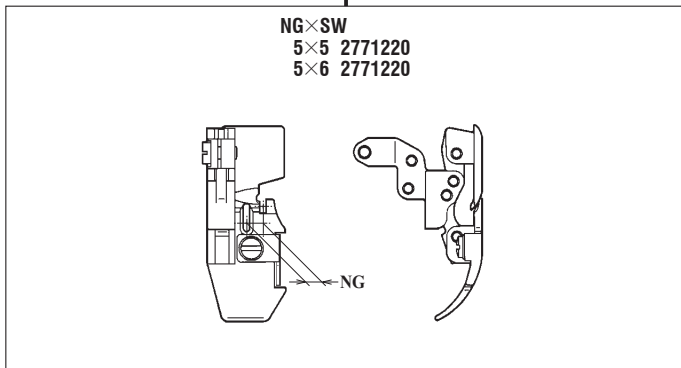
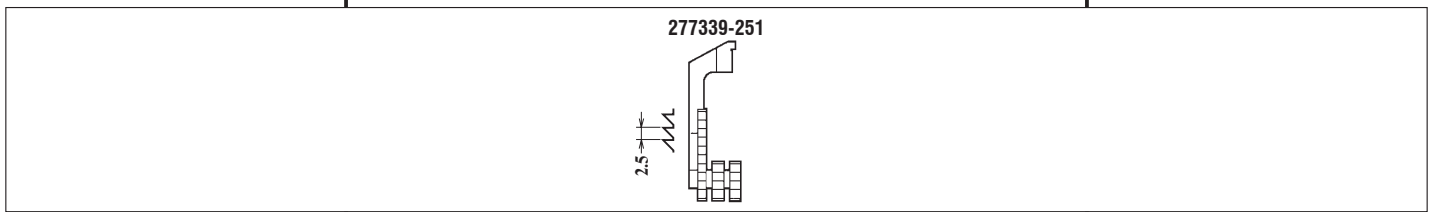
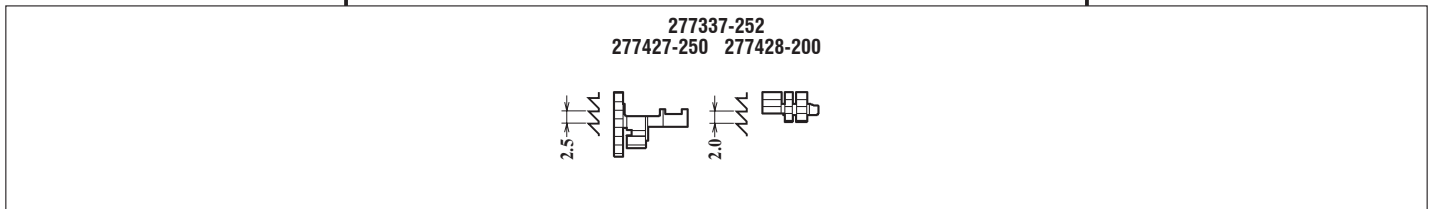
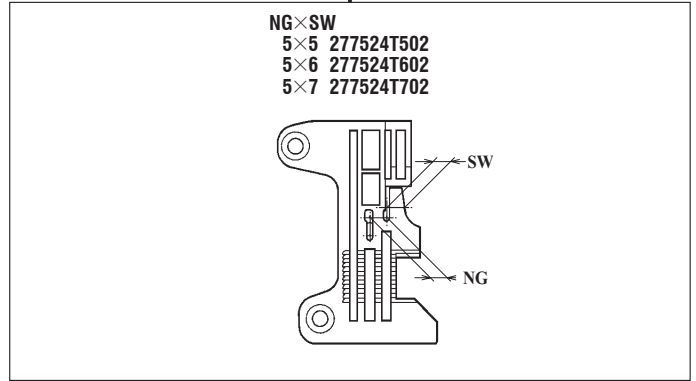
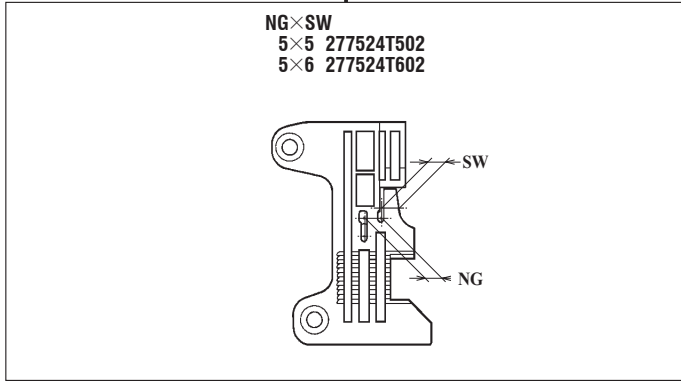

EX3215
EX3216-A04/435(K)

EX3215H
EX3216H-A05/535(K)

NG
5 277029-920

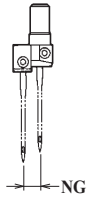

NG
5 277073-920

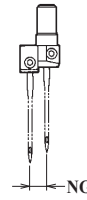

EX3215
2770140 #1



EX3216
2770110 #3

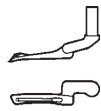

EX3215
277014A1 #8

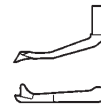

EX3216
2770170 #11

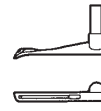

2770150



277018-C0

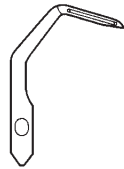

277015A0

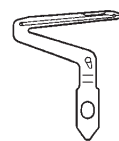

277018-C0

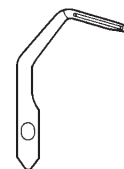

-A04/435
-A05/535

-A04/435K
-A05/535K

2770000



2116621

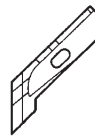

2770091



地縫用 (厚~極厚生地)
PLAIN SEAMING
(HEAVY~EXTRA HEAVY WEIGHT FABRIC)

地縫用 (極厚生地)
PLAIN SEAMING
(EXTRA HEAVY WEIGHT FABRIC)

EX3215-42/233(K)
EX3216

EX3215-43/335(K)
EX3216

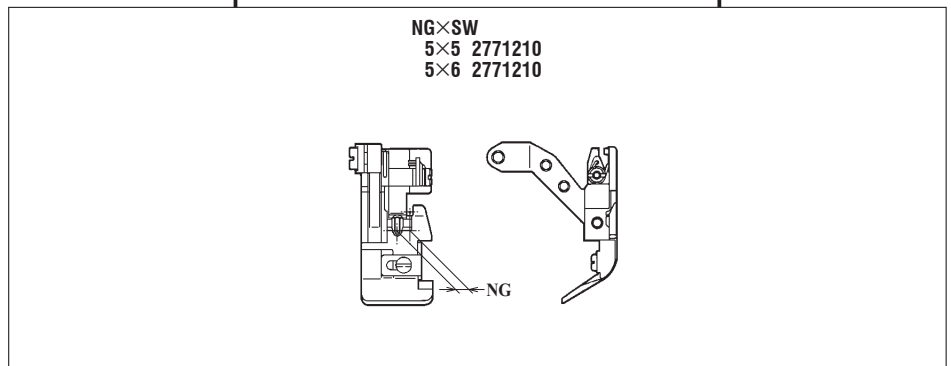
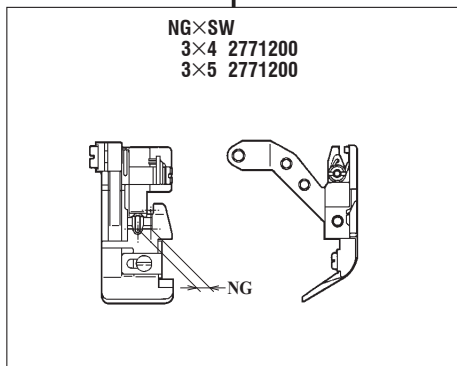
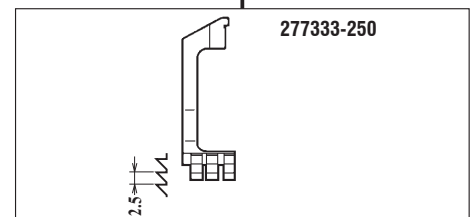
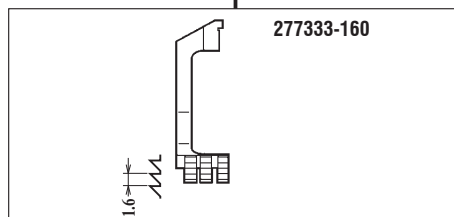
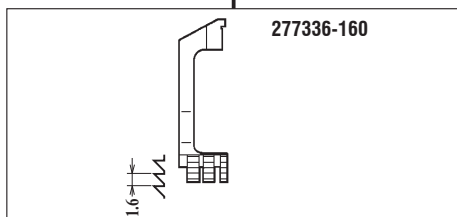
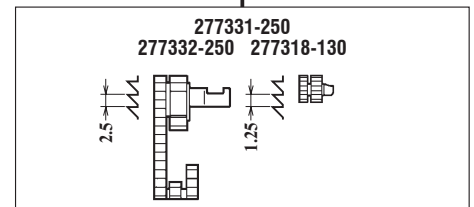
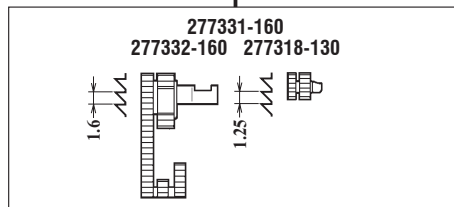
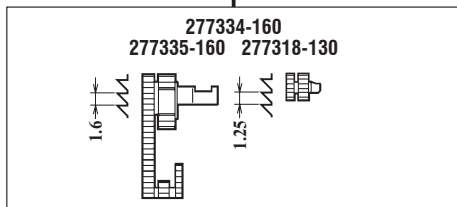
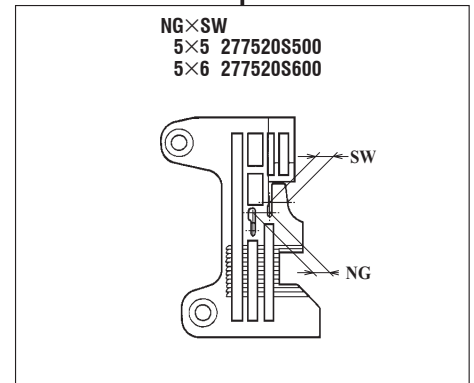
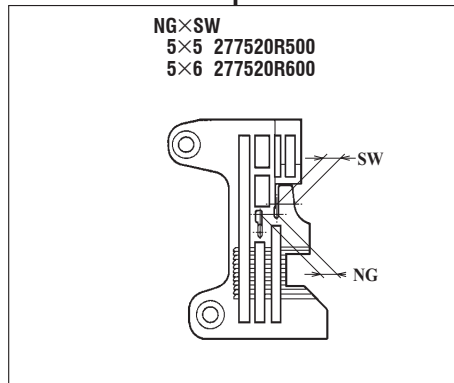
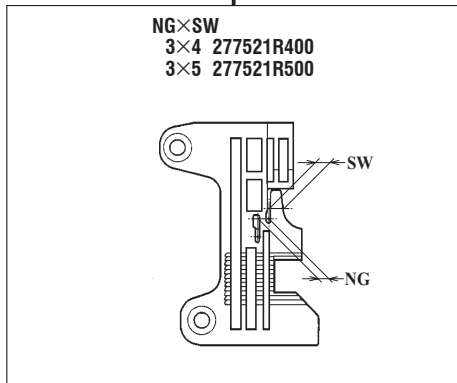

EX3215-42/233(K)
EX3216

EX3215-43/335(K)
EX3216

NG
3 277027-921

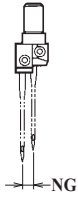

NG
5 277028-920

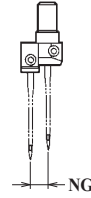

EX3215 277014B0 #9
EX3216 277010A0 #5

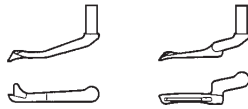

EX3215 277014A1 #8
EX3216 2770100 #2

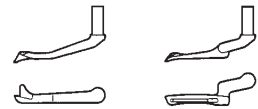

2770150

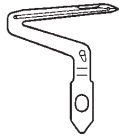

2770180

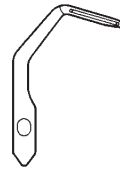

-42/233
-43/335

-42/233K
-43/335K

201121A0



2107550

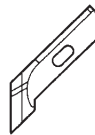

2022950

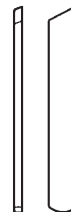

ヒダ取り用 (薄~中厚生地)
SHIRRING
(LIGHT~MEDIUM WEIGHT FABRIC)

ヒダ取り用 (中厚~厚生地)
SHIRRING
(MEDIUM~HEAVY WEIGHT FABRIC)

EX3215- 42P1/233(K)
EX3216- 42P1/233(K)
EX3215- 42P2/233(K)
EX3216- 42P2/233(K)

EX3215- 53/233(K)
EX3216- 53/233(K)

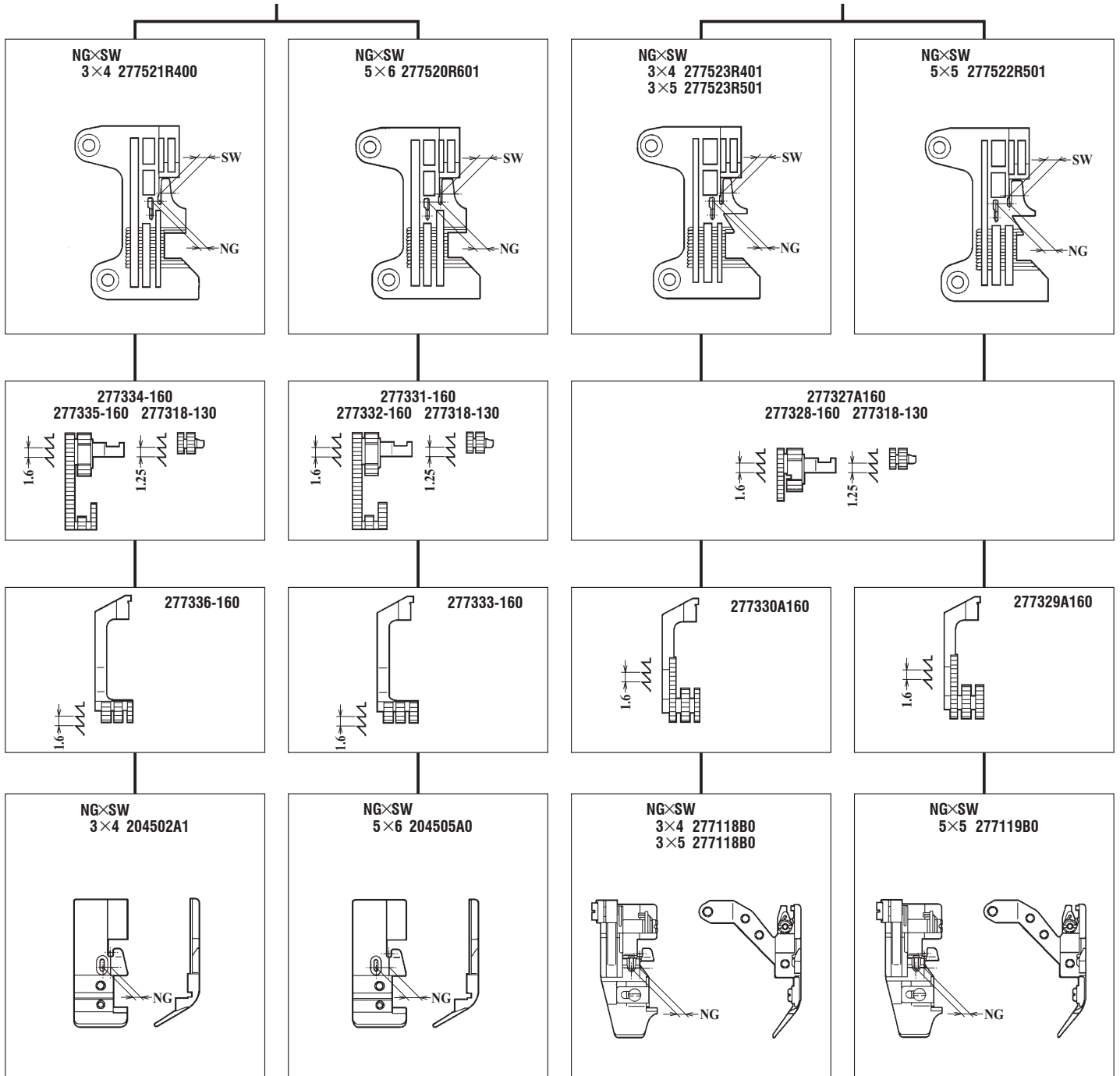

EX3215-42P1/233(K)
 EX3216-42P2/233(K)

EX3215-53/233(K)
 EX3216-53/233(K)

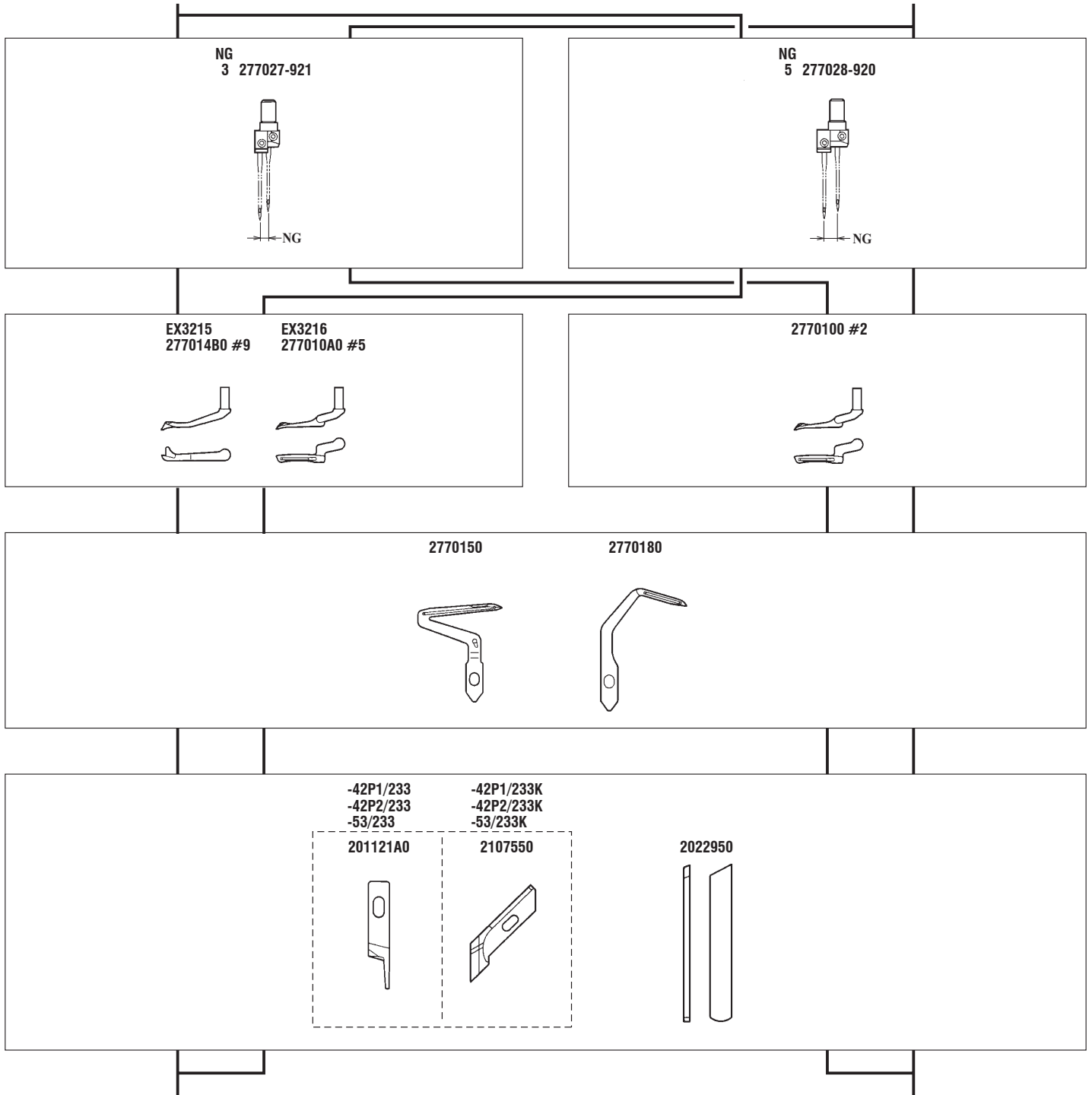

ヒダ取り・パイピング用 (薄~中厚生地)
 SHIRRING, PIPING
 (LIGHT~MEDIUM WEIGHT FABRIC)

テープ付用 (中厚~厚生地)
 ATTACHING TAPE
 (MEDIUM~HEAVY WEIGHT FABRIC)